



HTX

HYBRID TECHNOLOGY XTREME



THE ULTIMATE FUSION OF HID AND LED TECHNOLOGY



- 70W HID fast start internal ballast
- 80W LED
- Independently switched 3 mode operation
- 170mm reflector
- IP69K rated
- Genuine Gore® membrane
- 3 year warranty

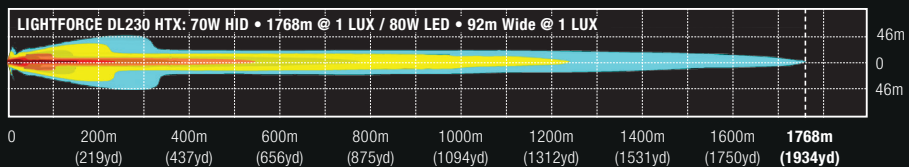

National Association of Testing Authorities Accredited, Australia 2015. Photometric testing performed by Photometric Solutions International Pty Ltd (PSI) Huntingdale VIC

lightforce.com

TECHNICAL SPECIFICATIONS



SPECIFICATIONS:

- LED power: 80W
- HID power: 70W
- Effective lumens: 8400
- Input voltage range: 10-16V DC
- Current draw: 11Amps @ 13.2V
- LED colour temperature: 5000K
- Matched HID colour temperature
- Input cable length: 450mm (17.71")
- Operating temperature: -40°C to 60°C
- Weight including bracket: 2.3kg (5.07lbs)

DIMENSIONS:

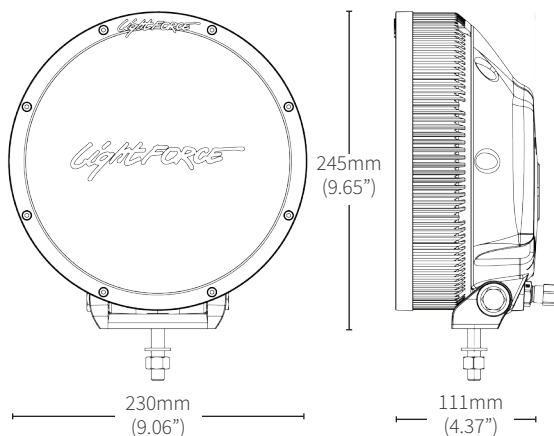

LIGHTFORCE DL230 HTX

The all new Australian made compact DL230 HTX is the ultimate fusion of HID and LED technology, providing the instant flood of LED combined with the unmatched long-distance of HID, eliminating the need for additional spotlights and bars beyond one set of HTX.

FEATURES:

- 70W HID bulb within 170mm reflector
- 20 x Lumiled LEDs providing flood beam pattern
- Lightweight glass filled nylon composite housing
- 6063 extruded aluminium for optimum heat dissipation
- IP69k rated to protect against moisture / contaminant ingress
- UV stable hard coated impact resistant polycarbonate lens
- Stainless steel hardware
- Independently switched three mode operation for complete control
 - LED – for instant wide beam
 - HID – for long distance
 - Combine the two for ultimate visibility
- High current waterproof connector
- Genuine Gore® waterproof membrane with mechanical seal
- Over, under and reverse voltage protection
- Thermal overload protection
- 3 year warranty

KIT INCLUSIONS:

- 1 x Lightforce DL230 HTX driving light
- 1 x Mounting bracket
- 1 x Mounting hardware
- Matching 4 pin waterproof harness adaptor
- Installation Instructions

OPTIONAL ACCESSORIES

- Dual switching dual relay harness (LFDLHDS)
- Anti theft nut kit (ATNSG)
- Stabiliser bracket (DL230TSB)

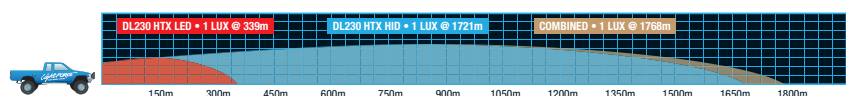

National Association of Testing Authorities Accredited, Australia 2015.
Photometric testing performed by Photometric Solutions International Pty Ltd (PSI) Huntingdale VIC

LightFORCE
PERFORMANCE LIGHTING

LightFORCE
PERFORMANCE LIGHTING
CUSTOM BUILT

Lightforce Australia Pty Ltd 11 Manton Street, Hindmarsh SA 5007 AUSTRALIA
Lightforce Performance Lighting Inc. 336 Hazen Lane, Orofino ID 83544 USA
p: +61 8 8440 0888 • f: +61 8 8346 0504 • www.lightforce.com