

50W LED FLOOD LIGHT

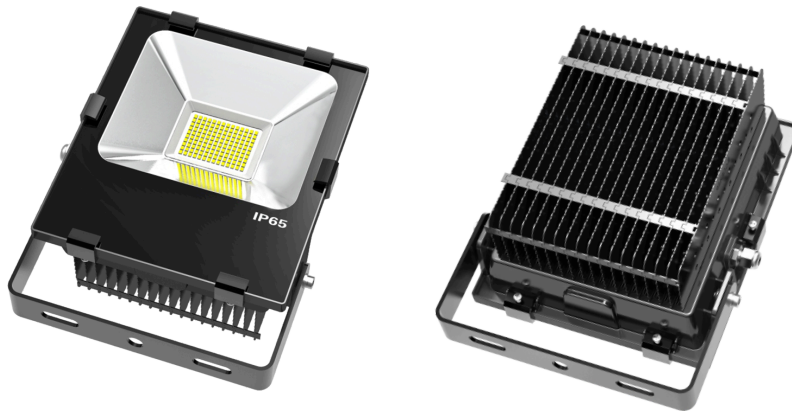

BMP-FLSMD90-50-1106-16



PRODUCT OVERVIEW

Input Voltage	220~240V
Power Consumption	50W
CCT	5500~6000K
CRI	Ra>70
IP Class	IP65

SPECIFICATIONS

Equivalent to (W)	100~150W
Wattage (W)	50W
Lumen Output (lm)	5,500lm
Lamp Efficiency (lm/W)	110lm/W
Voltage (V)	220~240V
On/Off Cycles (30Sec on/off)	20,000
Beam Angle	90°
Operating Temperature (°C)	-20~+60°C
LED Life Span	50,000 hours
Colour Description	Cool White
Colour Temperature (K)	5500~6000K
Colour Rendering Index (Ra)	>70
Warranty	5 years
Size (mm)	280 x 220 x 120mm
Dimmable	No
Weight (kg)	3.5kg
Respirator	Yes
Certification	SAA C-TICK

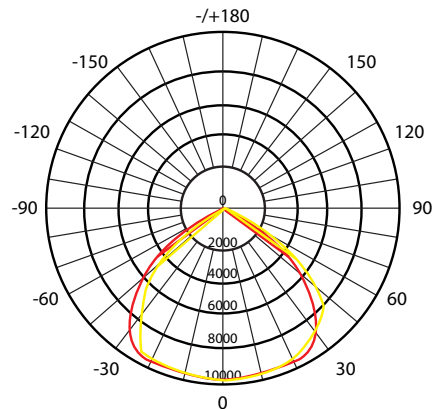
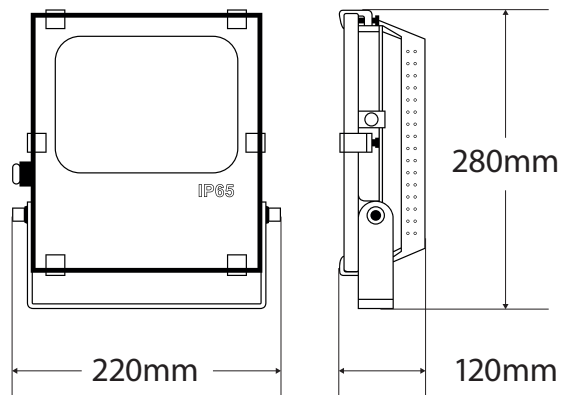

KEY FEATURES

Warranty	5 years
Power Saving	60% less energy consumption
Life Span	50,000 hours
Housing	High quality aluminium, oversized Fin cooling module, high coupling protection with high waterproof level
Instant	No warm up time
CRI	High CRI = better representation of colour spectrum
Low Heat	Highly efficient heat dissipation - safe to touch housing temperature with optical grade PMMA lens
Clean Light	Contains no mercury or hazardous materials (RoHS compliant) Emits no UV or IR radiation
Low Maintenance	Lower facility maintenance & repair costs
Other	Adopted SMD high light emitting diode, high light effect, wide beam angle 120°



BMP LED Lighting Pty Ltd Address: Unit 3 / 2 Tullamarine Park Road TULLAMARINE VIC AUSTRALIA 3043
 E : info@bmpled.com.au Ph : (03) 9335 2645 Fax : (03) 9335 4521 W : www.bmpled.com.au