

201 Series Single Combination

ECE/ADR
Approved

100%
Water Proof

5 Year
Warranty

- Horizontal LED Array
- Slimline Low Profile Design
- Shock, Dust & Water Proof
- 5 Year Warranty

Function	Stop/Tail/Indicator/Reverse		
Size	200mm x 50mm x 28mm		
Voltage	Multivolt 12-24V		
LED Qty	16		
Cable	40cm cable		

Draw	Stop	Tail	Ind
@13.8V	0.13A	0.02A	0.13A
@28V	0.40A	0.03A	0.40A

Approvals	Function	Category	CRN
ADR	Stop/Tail	49/00	46885
ADR	Indicator	06/00	46884



Inactive



Active

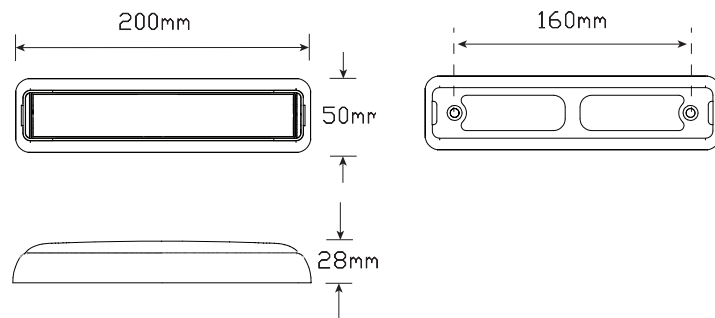

Part Number

- 201BSTIM** - Blister Single Pack
- 201BSTIMB** - Bulk Boxed
- 201CSTIM** - Blister Single Pack
- 201CSTI2** - Blister Twin Pack
- 201CSTIMB** - Bulk Boxed

Fitting Instructions

Horizontally mount bracket onto flat surface with screws provided, run wires through back and clip lens into place. Please refer to ADR 13/00.

200 Series Single Combination

**ECE/ADR
Approved**

**100%
Water Proof**

**5 Year
Warranty**

- Horizontal LED Array with Diamond Lens Pattern
- Slimline Low Profile Design
- Shock, Dust & Water Proof
- 5 Year Warranty

Function Stop/Tail/Indicator/Reverse

Size 200mm x 50mm x 28mm

Voltage Multivolt 12-24V

LED Qty 36

Cable 40cm cable

Draw	Stop	Tail	Ind	Rev
@13.8V	0.20A	0.02A	0.20A	0.23A
@28V	0.11A	0.02A	0.11A	0.14A

Approvals	Function	Category	CRN
ECE	Stop/Tail	R1-S1	11524
ECE	Indicator	2a-01	11524
ECE	Reverse	AR/00	11524



Inactive



Active

Part Number

200BIRSTME2 - Blister Twin Pack

200BIRSTMEB - Bulk Boxed

Fitting Instructions

Horizontally mount bracket onto flat surface with screws provided, run wires through back and clip lens into place. Please refer to ADR 13/00.

