

# 150W MODULAR HIGHBAY



## SPECIFICATIONS

Operating Voltage	AC 100V~277V
Power Efficiency	91%
Power Factor	0.95
Driver Current	860mA
LED Units	18 units × 3
System Power	150W
Luminous Efficacy	115lm/W
Initial Luminous Flux	17,250lm
Light Distribution Curve	12°, 25°, 40°, 60°, 90°
Colour Temperature	4000K / 5000K / 5700K
CRI	≥Ra70
Lighting Source	Philips-Lumileds
Working Environment	-40°C~+50°C, 10%~90%RH
Storage Temperature	-40°C~+50°C
LED life span	>50,000 hours
Body and shell materials	Aluminium Alloy
Dimensions	510 x 340 x 335mm
Surge Voltage	4KV
Net Weight	8.1kg
IP Protection Grade	LED Module IP68 Power Supply IP67
Quality Warranty	5 years

## Dimensions

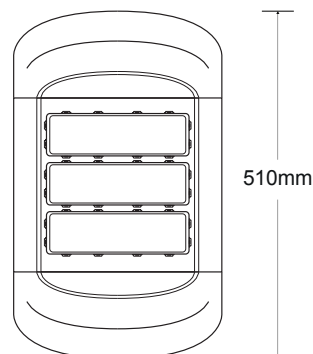
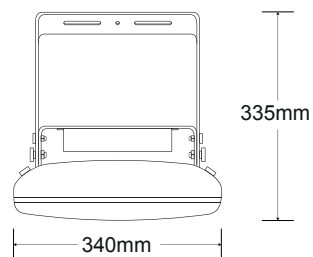

## KEY FEATURES

Modular pluggable technology, tool-free onsite maintenance

Honeycomb briquette burning effect and the whole structure cooling technology

Double-coupling IP68 protection, higher waterproof level

“Ultra Robust” module technology, single LED's or unit's damage doesn't affect other units' current

Multi-circuit constant-current driver, single module hot-pluggable

Ergonomic light distribution to achieve even illuminating effect

Free serialization and various power solutions